

MODEL: IF410/4-190, IF415/4-216, IF420/4-241 & IF425/4-248

MATERIALS	
Volute	ASTM-A48 CL-30
Impeller	ASTM-A48 CL-30
Main shaft	410 SS
Upper seal	Carbon-ceramic
Lower seal	*Carbon-ceramic
Bolts and nuts	18-8 SS
Wear ring	Bronze
Handle	304 SS
Coating	Epoxic

* Silicon Carbide (SiC) optional

REF.	in	mm
A`	25.9	660
B`	4.7	120
C`	16.4	418
D`	24.9	633
E`	11.8	300

Pump Height		
HP	in	mm
10	39.1	995
15		
20	41.1	1045
25	44.8	1140

Pump Weight		
HP	Lbs	Kg
10	451.9	205
15	462.9	210
20	549.7	248
25	639.3	290

REF.	in	mm
A	2.99	76
B	0.6	16
C	5.1	130
D	1.9	50
E	26.5	675
F	29.5	750
H	17	432
H	9.3	235
I	12.9	330
J	2.3	60
K	0.6	16
L	4.5	115
M	36	915
N	5.9	150
O	7.8	200
P	6.4	165
Q	7.4	190
R	3.9	100
S	7.4	190
T	8.4	215
U	15.9	405
V	25.9	659
W	11	280
X	8	205
Y	19	485
Z	30.9	785

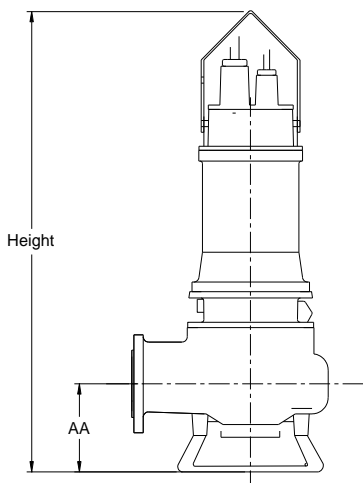
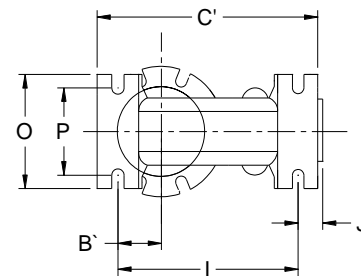
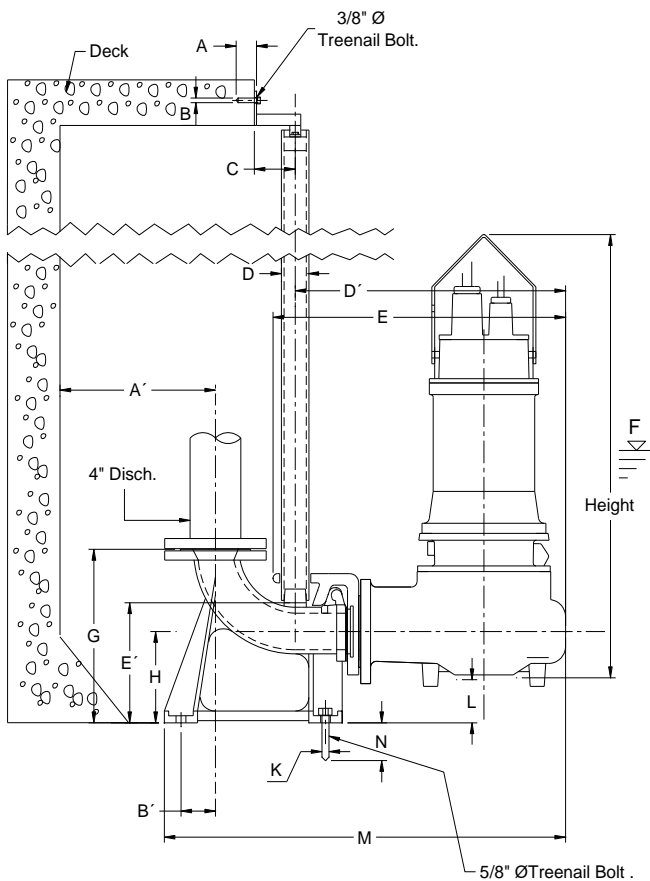

Installation		
AA	14.3 in	365 mm

