

No.	Part name	Material	QTY	Remark
01	Cable		1	
03	Upper cover	FC200	1	
06	Bracket	FC200	1	
07	Stator		1	
09	Shaft(with Rotor)	SUS403	1	
10A	Auto-cut		1	
11	Bearing fixer	SPCC	1	
12	Centrifugal switch		1	
14R	Capacitor		1	
14S	Start capacitor		1	
16	Motor frame	SUS304	1	
17	Lubricant			
19	Bearing bracket	FC200	1	

No.	Part name	Material	QTY	Remark
20A	Upper bearing		1	
20B	Lower bearing		1	
21	M.seal	CA VS CE SIC VS SIC	1	
25	Oil seal	NBR	1	
26	Casing	FC200	1	
27	Impeller	FC200	1	
28	Casing	FC200	1	
30	Footing	FC200	1	
31	Strainer	SUS304	1	
41	Handle	SUS304	1	
46	Impeller key	SUS304	1	
47	Packing			

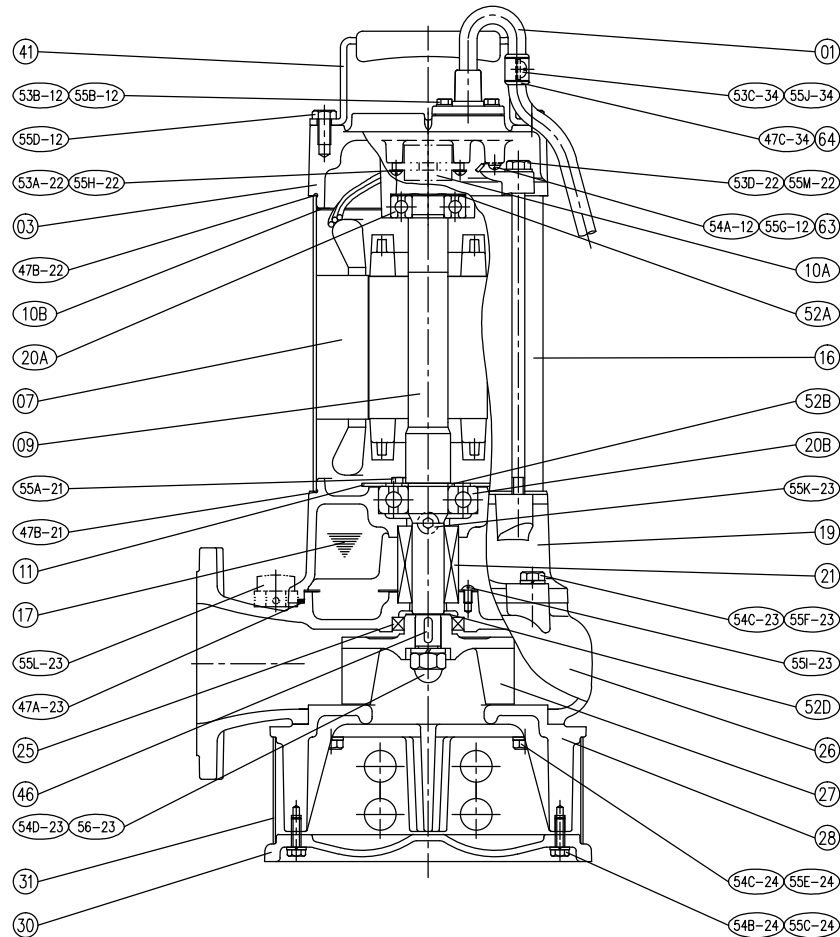

No.	Part name	Material	QTY	Remark
01	Cable		1	
03	Upper cover	FC200	1	
07	Stator		1	
09	Shaft(with Rotor)	SUS403	1	
10A	Auto-cut		1	
10B	Auto-cut plate		1	
11	Bearing fixer	SPCC	1	
16	Motor frame	SUS304	1	
17	Lubricant			
19	Bearing bracket	FC200	1	
20A	Upper bearing		1	
20B	Lower bearing		1	
21	M.seal	CA VS CE SIC VS SIC	1	

No.	Part name	Material	QTY	Remark
25	Oil seal	NBR	1	
26	Casing	FC200	1	
27	Impeller	FC200	1	
28	Casing	FC200	1	
30	Footing	FC200	1	
31	Strainer	SUS304	1	
41	Handle	SUS304	1	
46	Impeller key	SUS304	1	
47	Packing			